

INTRODUCTION

Thank you for purchasing the Myron L[®] Company Ultrapen™ PT5 Dissolved Oxygen (DO) Pen. This instrument is designed to be extremely accurate, fast, and simple to use in diverse water quality applications. Advanced features include:

- Real time readings.
- A proprietary sensor design and highly stable microprocessor-based circuitry that measures DO with an accuracy of up to $\pm 2\%$.
- Temperature compensation algorithm that dynamically corrects for changes in membrane temperature during measurements.
- Adjustment for Altitude and sample Salinity.
- Three calibration methods, **AIR** (Water Saturated Air), **WATER** (Air Saturated Water), and **ZERO** (0 ppm DO).
- True one-handed operation.
- A rugged, reliable design with an aircraft aluminum body.
- Waterproof housing.
- Replacement membranes contained in easy to install, screw-on caps.

QUICK REFERENCE INSTRUCTIONS

1. Push and release the push button to turn the PT5 ON.
2. While the LED flashes rapidly: Dip the pen in sample solution so the sensor is totally submerged.
3. While the LED flashes slowly: Swirl the pen in sample, keeping sensor submerged.
4. In HOLD mode – Real time readings are displayed until the LED turns solid ON. The display holds the final reading briefly then the PT5 turns OFF.
5. In LIVE Mode – The PT5 will display constant, real time measurements for up to 5 minutes then turn OFF.

ULTRAPEN FEATURES

1. **PUSH BUTTON**– Turns the PT5 ON, selects instrument settings, and initiates calibration.
2. **BATTERY CAP**– Unscrew to access battery for replacement.
3. **DISPLAY**– Displays measurements, menu options, battery indicator, and firmware revision (during power-up).
4. **LED INDICATOR LIGHT**– Indicates when to dip the PT5 in solution, when the measurement is in progress, and when to remove the PT5 once the measurement is complete.
5. **DO SENSOR**– Contains the zinc anode, silver cathode, and is filled with electrolyte solution. Electrochemically measures presence of dissolved oxygen molecules that cross the permeable membrane into the sensor's electrolyte solution.
6. **MEMBRANE CAP** – Replaceable cap that contains the DO membrane.
 - Use caution not to touch the membrane, as oil from your fingers will compromise the membrane.
7. **THERMISTOR** – Measures temperature of water sample.
8. **DO MEMBRANE** – Membrane is built into the membrane cap.
9. **CAP STOP** – Shows how far to push the hydration cap when putting it on the PT5.
 - DO NOT** push the hydration cap beyond the cap stop as sensor damage may occur.
10. **HYDRATION CAP** – Protects sensor and contains water vapor when performing **AIR** calibrations. To remove, wiggle the hydration cap back and forth while pulling off.
 - Use caution not to spill water. Verify the sensor remains fully inserted into the PT5. If not, reinstall per DO sensor replacement instructions (see Section II of MAINTENANCE on page 7).
 - To replace, fill the hydration cap with enough clean water (preferably DI, RO, or purified water) to soak the sponge inside. Wiggle the hydration cap back and forth, while pushing it on.

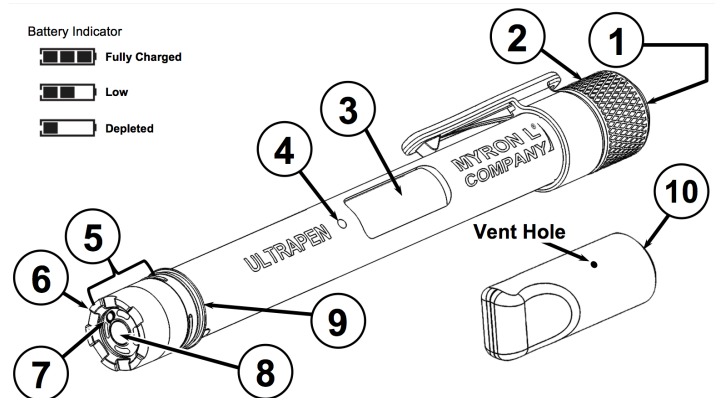

OPERATION INSTRUCTIONS

NOTE: In all menus, selecting “ESC” immediately powers the PT5 OFF without saving changes to the settings.

I. TEMPERATURE UNIT SELECTION, °C (Celsius) / °F (Fahrenheit)

The PT5 allows you to select the type of units for displaying temperature.

To select the Temperature Units:

1. Press and release the push button to turn the PT5 ON.
2. Press and hold the push button to enter menu mode.
3. Release the push button while “°C/°F TEMP” is displayed.
4. The display will alternate between “PUSHnHLD” and “°C/°F TEMP”.
5. Press and hold the push button. The display will alternate between the following:
 - “°C” (Celsius).
 - “°F” (Fahrenheit).
 - “ESC”.
6. Release the push button when desired unit is displayed.
 - “SAVEd °C” or “SAVEd °F” will display, then the PT5 will power OFF.

II. DISSOLVED OXYGEN PARAMETER SELECTION (ppm Concentration/% Saturation):

The PT5 allows you to choose which of its DO units of measure to display when making a measurement, DO Concentration, DO Saturation or both.

To select a parameter for display:

1. Press and release the push button to turn the PT5 ON.
2. Press and hold the push button to enter menu mode.
3. Release the push button while “PAr SEL” is displayed.
4. The display will alternate between “PUSHnHLD” and “PAr SEL”.
5. Press and hold the push button. The display will alternate between the following:
 - “Conc ppm” (displays DO Concentration and Temperature).
 - “Sat %” (displays DO Percent Saturation and Temperature).
 - “Default” (display flashes between DO Concentration (ppm), DO Saturation (%) and Temperature).
 - “ESC”.
6. Release the push button when desired parameter type is displayed.
 - “SAVEd” will display, then the PT5 will power OFF.

III. MODE SELECTION (LIVE / HOLD):

The PT5 allows you to select between two measurement modes:

HOLD mode (Default) – Real-time readings are displayed until the LED turns solid ON. The display holds the final reading briefly then the PT5 turns OFF.

LIVE mode – Real-time readings are displayed continuously for up to 5 minutes (user may adjust auto timeout duration from 60 up to 300 seconds).

- While in LIVE measurement mode, a press and release of the push button will turn your PT5 OFF immediately.

To select the mode:

1. Press and release the push button to turn the PT5 ON.
2. Press and hold the push button to enter menu mode.
3. Release the push button while “ModE SEL” is displayed.
4. The display will alternate between “ModE SEL” and “PUSHnHLD”.
5. Press and hold the push button. The display will alternate between “Hold”, “LIVE”, and “ESC”.
6. Release the push button when the desired mode is displayed.
 - If HOLD is selected: “SAVEd” will display, then the PT5 will power OFF.
 - If LIVE is selected: The display will alternate between “[value] SEC” and “PUSHCont”. Press and release repeatedly or press and hold to adjust the auto-off duration. When the desired auto-off duration is displayed, let the PT5 time out.

IV. ALTITUDE ADJUSTMENT:

Altitude should be adjusted to match the test location. Altitude is set in 100 ft. increments.

1. Press and release the button to turn the PT5 ON.
2. Press and hold the push button to enter menu mode.
3. Release the push button while “ALt SEL” is displayed.

Myron L[®] Company – ULTRAPENT™ PT5 – Operation Manual
Dissolved Oxygen (DO) and Temperature Pen

4. Adjust the altitude by one of the following methods:
 - Press and release the push button repeatedly to slowly increase the altitude, or;
 - Press and hold the push button to quickly increase the altitude, then release the button when the desired altitude is displayed.
 - In either case, the altitude selection will begin at -2000 ft., increase to 15,000 ft., and restart at -2000 ft.
5. If you release the push button and don't re-push it, the PT5 will begin flashing between the current altitude setting and "PUSHCont".
 - Press the push button to continue changing the altitude, or:
 - Wait for several seconds and the display will show "SAVEd", then the PT5 will power OFF.

V. SALINITY ADJUSTMENT:

Salinity should be adjusted to match the Salinity of the test solution. Salinity is set in 1 ppt increments.

1. Press and release the push button to turn the PT5 ON.
2. Press and hold the push button to enter menu mode.
3. Release the push button while "SAL SEL" is displayed.
4. Adjust the salinity by one of the following methods:
 - Press and release the push button repeatedly to slowly increase the salinity, or;
 - Press and hold the push button to quickly increase the salinity, then release the button when the desired salinity is displayed.
 - In either case, the salinity selection will begin at 0 ppt, increase to 50 ppt, and restart at 0 ppt.
5. If you release the push button and don't re-push it, the PT5 will begin flashing between the current salinity and "PUSHCont".
 - Press the push button to continue changing the salinity, or:
 - Wait for several seconds and the display will show "SAVEd", then the PT5 will power OFF.

DO MEASUREMENT

I. MEASUREMENT SETUP

The following steps should be taken prior to performing a measurement with your PT5:

1. Fill the DO sensor with electrolyte and allow it to stabilize (see MAINTENANCE section III below).
2. Adjust the PT5 Altitude to match that of the measurement location (see OPERATION Instructions section IV above).
3. Adjust the PT5 Salinity to match that of the measurement solution (see OPERATION Instructions section V above).
4. Perform a **ZERO** calibration and an **AIR** (water-saturated air) calibration of the PT5 (see CALIBRATION Instructions sections I and II).

II. DO MEASUREMENT

1. Press and release the push button to turn the PT5 ON.
2. Dip the PT5's sensor in the solution to be tested and swirl it around.
3. Continue to swirl the PT5 sensor in the solution while the measurement is taking place.

The following table explains what the LED Indicator Light signals indicate and gives the duration of each signal:

LED SIGNAL	ACTION	DURATION
Rapid Flashing	Dip sensor in solution and swirl.	6 sec
Slow Flashing	Measurement in process; continue to swirl sensor in solution. In HOLD mode real-time readings are displayed until the LED is ON solid. In LIVE mode real-time readings are displayed until the PT5 turns OFF.	20 -120 sec in HOLD mode Up to 5 min in LIVE mode
Solid Light (HOLD mode only)	Measurement is complete. Values are displayed until the PT5 turns OFF.	6 sec

NOTE: You can turn OFF the unit at any time during live measurement with a simple press and release of the push button.

- For best results when measuring solution at the extremes of the specified temperature or DO range **ALWAYS** perform a **TEMPERATURE CONTROLLED, FULL** calibration (See section IV of CALIBRATION instructions below) and allow the PT5 to equilibrate by submerging the sensor in the sample solution for 1 minute prior to taking a measurement.
- If the expected measurement is < 3 ppm it is particularly important to perform the **ZERO** calibration described in the CALIBRATION Section I below.
- **ALWAYS** make sure the DO sensor is completely submerged in the solution being tested.

CALIBRATION

- It is recommended that the PT5 be calibrated before each series of tests.
- Verify calibration if readings are not as expected. If the expected measurement is < 3 ppm, **ZERO** point calibration is particularly important.

ACCURACY AFTER CALIBRATION:

- **ZERO Calibration + AIR Calibration @ 25°C:**
 - **Saturation:** 0-100%: ±45 counts; >100%: ± 4.5% of the reading (>5°C to ≤ 55°C)
 - **Concentration:** ±0.45 ppm or ± 4.5 % of the reading, whichever is greater (up to 40°C).
- **ZERO Calibration + WATER Calibration @ 25°C:**
 - **Saturation:** 0-100%: ± 35 counts; >100%: ± 3.5% of the reading (>5°C to ≤ 55°C)
 - **Concentration:** ±0.35 pm or ± 3.5 % of the reading, whichever is greater (up to 40°C).
- **TEMPERATURE CONTROLLED, FULL Calibration @ >5°C to ≤ 55°C:**
 - **Saturation:** 0-100.0%: ± 20 counts; >100%: ± 2% of the reading (>5°C to ≤ 55°C)
 - **Concentration:** ±0.2ppm or ±2% of the reading, whichever is greater (up to 40°C).

I. ZERO CALIBRATION

1. Prepare the PT5 for calibration by dipping the sensor in clean water (preferably DI, RO, or purified water).
2. Carefully blot the sensor membrane with a soft, clean, lint-free cloth or tissue to remove any water drops.
3. Pour the DO zero calibration solution, part # DOSOL, into a beaker or cup.
4. Completely submerge the sensor in zero calibration solution for 5 minutes.
5. Keeping the sensor submerged in the zero calibration solution, press and release the push button to turn the PT5 ON.
6. Press and hold the push button. Release the push button while “CAL” is displayed.
7. Press and hold the push button. The display will alternate between the following:
 - “0 CAL”; “Air CAL”; “H2O CAL”; “ESC”.
8. Release the push button when “0 CAL” is displayed.
9. The PT5 will perform the calibration, then display “SAVED”, and turn OFF.
10. Verify the calibration by taking a measurement of the zero calibration solution.
 - The result should be 0 ppm.

II. AIR CALIBRATION (WATER-SATURATED AIR)

1. Prepare the PT5 for calibration by dipping the sensor in clean water (preferably DI, RO, or purified water).
2. Carefully blot the sensor membrane with a soft, clean, lint-free cloth or tissue to remove any water drops.
3. Make sure the hydration cap is filled with enough DI, RO, or distilled water to soak the sponge inside.
4. Hold the PT5 upright with the DO sensor down and insert the sensor into the hydration cap (this will create a water-saturated Air environment).
 - **ONLY** insert the sensor into the hydration cap until the lip of the cap is located halfway up the sensor body, just enough to create a good seal. **DO NOT** obscure the vent hole in the hydration cap.
5. Continuing to hold the PT5 upright, press and release the push button to turn the PT5 ON.
6. Press and hold the push button. Release the push button while “CAL” is displayed.
7. Press and hold the push button. The display will alternate between the following:
 - “0 CAL”; “Air CAL”; “H2O CAL”; “ESC”.
8. Release the push button when “Air CAL” is displayed.
9. The PT5 will perform the calibration, then display “SAVED”, and turn OFF.
10. Verify the calibration by performing a Saturation measurement with the hydration cap still in place.
 - The result should be 104% ±2%.

III. WATER CALIBRATION (AIR-SATURATED WATER)

1. Prepare an air-saturated water solution by bubbling air through DI, RO, or distilled water for a minimum of 30 minutes.
 - Continue bubbling air through the water during the entire calibration.
2. Keeping the sensor submerged in the oxygenated water, press and release the push button to turn the PT5 ON.
3. Press and hold the push button. Release the push button while “CAL” is displayed.
4. Press and hold the push button. The display will alternate between the following:
 - “0 CAL”; “Air CAL”; “H2O CAL”; “ESC”.
5. Release the push button when “H2O CAL” is displayed.
6. When the LED begins flashing rapidly, completely submerge the PT5’s DO sensor in the water (away from the bubble stream) and swirl around in the water to dislodge any bubbles that may collect on the sensor.
7. The PT5 will perform the calibration, then display “SAVED”, and turn OFF.
8. Verify the calibration by performing Saturation measurement of the air-saturated water. The result should be 100% saturation.

IV. TEMPERATURE CONTROLLED, FULL CALIBRATION PROCEDURE

A. EQUIPMENT AND SUPPLIES REQUIRED

General

- 1 ea. – Hot Plate with Magnetic Stirrer; Must be capable of sustaining temperature levels to $\pm 1^{\circ}\text{C}$.
For solution temperatures below ambient, a refrigerated, circulating water bath should be used (not shown).
- 1 ea. – Thermometer (Digital or Mercury Column). Must be accurate to at least $\pm 1^{\circ}\text{C}$, preferably $\pm 0.25^{\circ}\text{C}$
- 1 ea. – Glass Beaker (≈ 300 ml): For rinsing sensor before and after ZERO calibration.
- 1 ea. – Magnetic Stir Bar
- 1L – Water (DI, RO, or distilled).

For ZERO Calibration

- 1 ea. – Glass Beaker (≈ 100 ml)
- 2 oz. (≈ 59 ml) – 0 ppm Dissolved Oxygen Calibration Solution (Myron L[®] Company P/N **DOSOL**).

For WATER Calibration

- 1 ea. – Glass Beaker ($\approx 1\text{L}$)
- 1 ea. – Aquarium Air Pump with 1L / min capacity or better.
- 1 ea. – Aquarium Air Stone: Approximately 1.5" L x 0.49" W (3.9 cm L x 1.3 cm W)
- Aquarium Air Tubing (As required)

B. GENERAL NOTES AND PREPARATION

- Both the **ZERO** and **WATER** calibration must be performed at the same temperature as the target sample solution to be tested.
- Once you've calibrated the PT5 at a specific temperature, if the target solution changes temperature more than 5°C , the PT5 should be recalibrated at the new temperature.
- It is important to make sure that the PT5 sensor is completely submerged during the calibration process.
- All glassware should be clean and dry before use.
- Prepare the rinse water: Pour approximately 200 ml of DI, RO, or distilled water into the 300 ml beaker.
- Attach the air stone to the aquarium pump with the aquarium tubing.

C. ZERO CALIBRATION

1. Pour the 2 oz. of zero calibration solution into the 100 ml beaker.
2. Place the beaker of zero calibration solution onto the hot plate.
3. Turn ON the hot plate and set it for the target temperature.
4. Let the ZERO calibration solution stabilize at the target temperature.
 - Verify the temperature of the solution using the thermometer (not shown in diagram).
 - Make sure the solution is within $\pm 1^{\circ}\text{C}$ of the target temperature before proceeding.
5. Rinse the PT5 sensor by swirling it in the rinse water for several seconds.
6. Carefully blot the sensor membrane with a soft, clean cloth or tissue to remove any water drops.
7. Completely submerge the sensor in zero calibration solution.
8. Wait 5 minutes for the PT5 sensor to equilibrate.
9. Keeping the sensor submerged in the zero calibration solution, press and release the push button to turn the PT5 ON.
10. Press and hold the push button to enter menu mode. Release the push button while "CAL" is displayed.
11. Press and hold the push button. The display will alternate between the following:
 - "0 CAL", "Air CAL", "H2O CAL", and "ESC".
12. Release the push button when "0 CAL" is displayed.
 - Calibration may take as long as 3 minutes or more.
13. When completed, the PT5 will display "SAVED", and turn OFF.
14. Remove the beaker of zero calibration solution from the hot plate.
15. Rinse PT5 in clean water (preferably DI, RO, or distilled water).
16. Fill the hydration cap with enough clean water to soak the sponge inside and place it onto the DO sensor all the way to the cap stop.
17. Allow the DO sensor to stabilize to the water-saturated air inside the hydration cap for 5-10 minutes.
18. Proceed to the **WATER CALIBRATION** (Air-Saturated Water).

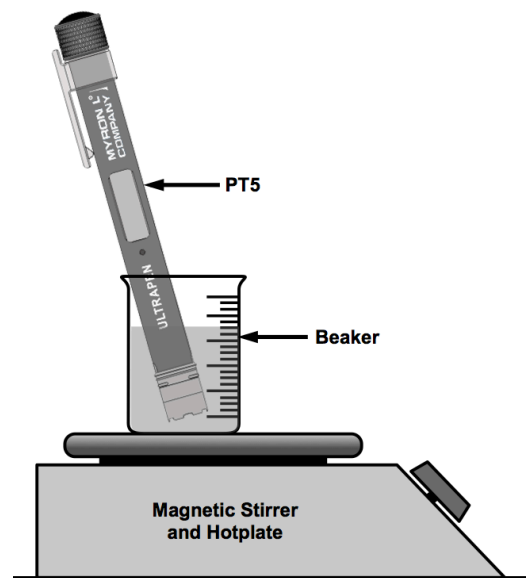

V. WATER CALIBRATION (Air-Saturated Water)

1. Pour 800 ml of DI, RO, or distilled water into the 1L beaker.
2. Place the beaker of water onto the hot plate.
3. Drop the magnetic stir bar into the beaker.
4. Place the Air stone into the beaker of water.
 - Make sure it is at the bottom of the beaker but will not interfere with the stir bar.
5. Turn ON the aquarium pump.
 - The bubbles should be small and numerous.
 - If there are only a few, large bubbles, replace the air stone with a new one.
6. Turn ON the hot plate and set it for the target temperature.
7. Turn ON the stirrer, set to approximately 500 rpm.
8. Let the air bubble through the water for at least 30 minutes.
9. Verify the temperature of the solution using the thermometer (not shown in diagram).

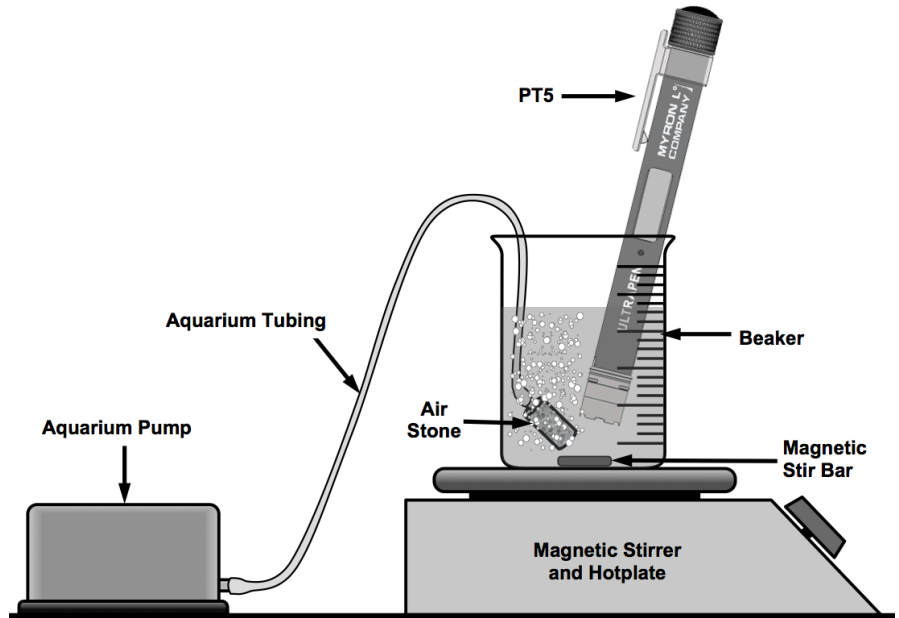

- Make sure the solution is within $\pm 1^{\circ}\text{C}$ of the target temperature before proceeding.
10. Rinse the PT5 sensor by swirling it in the rinse water for several seconds.
 11. Carefully blot the sensor membrane with a soft, clean, lint-free cloth or tissue to remove any water drops.
 12. Completely submerge the sensor in the aerated, temperature-controlled water (DI, RO or distilled).
 - DO NOT:** Let the sensor interfere with the stir bar motion.
 - DO NOT:** Hold the sensor directly over the air stone or in the bubble stream
 13. Wait 5 minutes for the PT5 sensor to equilibrate.
 14. Keeping the sensor submerged in the aerated water solution, press and release the push button to turn the PT5 ON.
 15. Press and hold the push button to enter menu mode.
 16. Release the push button while “CAL” is displayed.
 17. Press and hold the push button. The display will alternate between the following:
 - “0 CAL”, “Air CAL”, “H2O CAL”, and “ESC”.
 18. Release the push button when “H2O CAL” is displayed.
 19. Swirl the PT5 constantly while it performs the calibration.
 - Calibration may take as long as 3 minutes or more.
 20. When completed, the PT5 will display “SAVED”, and turn OFF.

VI. FACTORY CALIBRATION

The PT5 can be returned to factory default calibration settings using the FAC CAL function. This will erase any stored calibration data.

NOTE: Default factory calibration resets the electronics only and does NOT take the condition of the sensor or the sensor membrane into consideration.

To return your PT5 to factory calibration:

1. Press and release the push button to turn the PT5 ON.
2. Once the instrument turns ON, press and hold the push button
3. Release the push button when “FAC CAL” displays.
 - The display will alternate between “PUSHnHLD” and “FAC CAL”.
4. Press and hold the push button. “SAVED” displays indicating the PT5 has been reset to its factory calibration.
 - ***ALWAYS perform a ZERO Calibration or a Full, Temperature Controlled Calibration after FAC CAL has been used to reset the PT5.***

TROUBLESHOOTING

I. TROUBLESHOOTING GUIDE

Symptom	Possible Cause	Remedy
Error message during calibration	Sensor was not properly submerged in solution during calibration.	Repeat calibration and ensure sensor is submerged in solution prior to LED flashing slowly.
	Improper calibration solution.	Verify you are using the proper calibration solution.
	Temperature out of range.	Verify temperature is within range.
	Sensor needs cleaning	Clean sensor (see MAINTENANCE section VI).
	Membrane is damaged	Replace membrane (see MAINTENANCE section V).
	Sensor is damaged	If cleaning sensor does not correct error, replace sensor (see MAINTENANCE section II).
Readings are not as expected	Sensor was not properly submerged in solution during measurement.	Repeat measurement and ensure sensor is submerged in solution prior to LED flashing slowly.
	Sensor needs cleaning	Clean sensor (see MAINTENANCE section VI).
	Membrane is damaged	Replace membrane (see MAINTENANCE section V).
	Sensor is damaged	If cleaning sensor does not correct error, replace sensor (see MAINTENANCE section II).
Displays a single dash (-)	Temperature is out of specified range	If the solution temperature is within the specified range, the sensor may be damaged, replace sensor.
Displays two dashes (- -)	DO is out of specified range	If you believe solution is within the specified range, clean and calibrate the PT5 and retest solution.

II. SENSOR CHECK

The sensor check is a built in feature to check the amplitude of the signal from the sensor. This is used as a troubleshooting tool only, and is not designed to detect all sources of failure. To perform a sensor check:

1. Prepare the PT5 by dipping the sensor in clean water (preferably DI, RO, or purified water).
2. Carefully blot the sensor membrane with a soft, clean, lint-free cloth or tissue to remove any water drops.
3. Make sure the hydration cap is filled with enough DI, RO, or distilled water to soak the sponge inside.
4. Hold the PT5 upright with the DO sensor down and insert the sensor into the hydration cap (this will create a water-saturated Air environment).
 - **ONLY** insert the sensor into the hydration cap until the lip of the cap is located halfway up the sensor body, just enough to create a good seal. **DO NOT** obstruct the vent hole in the hydration cap.
5. Continuing to hold the PT5 upright with the DO sensor down, press and release the push button to turn the PT5 ON.
6. Press and hold the push button to enter menu mode.
7. Release the push button while “SEnSor ✓” is displayed.
8. The LED will flash rapidly while the self-check is being performed, then results will be displayed.
 - “PASS” indicates there was sufficient signal strength.
 - “FAIL” indicates the sensor is not in optimal condition. The sensor may need to be cleaned, the membrane may need to be replaced, or the sensor may need to be replaced (See MAINTENANCE section below).

MAINTENANCE

NOTE: The PT5 **MUST** be recalibrated any time: the DO sensor is replaced; the DO membrane or the electrolyte is replaced, or; the Zinc electrode is cleaned.

I. ROUTINE MAINTENANCE

1. After each use **ALWAYS** rinse the DO sensor with DI, RO, or distilled water and then carefully blot the sensor membrane with a soft, clean cloth or tissue to remove any water drops.
2. **ALWAYS** replace the hydration cap on the DO sensor after each use.
3. Do not drop, throw, or otherwise strike the PT5. This voids the warranty.
4. Do not store the PT5 in a location where the ambient temperatures exceed its Operating/Storage Temperature limits.
5. **DO NOT** remove the DO sensor membrane except to replace it with a new membrane or to replace / refill the electrolyte.
 - Unnecessarily removing and replacing the same membrane can degrade the quality of the DO measurements.

Dissolved Oxygen (DO) and Temperature Pen

II. REPLACING OR REINSTALLING THE DO SENSOR

- Always Replace the sensor dry and fill with electrolyte after installation.
- Follow the instructions that come with your replacement sensor.
- Only remove/replace the DO sensor in a CLEAN and DRY environment.

To remove the DO sensor:

1. Remove the hydration cap.
2. Remove the membrane cap and empty the electrolyte well of all electrolyte.
3. Make sure the PT5 (including the DO sensor) is clean and dry.
4. Loosen the battery tray (to allow pressure equalization).
5. Firmly grasp the DO sensor body and slowly pull the sensor out. DO NOT allow electrolyte into the body of the PT5.
6. To install a new DO sensor: Line up the alignment tabs on the DO sensor with the alignment slots on the PT5 unit. Gently push the DO sensor into position, and then close the battery cap.

III. REPLACING / REFILLING THE DO SENSOR ELECTROLYTE SOLUTION

NOTES:

- When excess bubbles have formed inside the electrolyte well, you should refill the electrolyte solution. Minimizing air bubbles inside the electrolyte well will improve accuracy.
- Always avoid touching the membrane.
- When too many white zinc oxide particles have formed inside the electrolyte solution, or readings are not as they should be, replace the electrolyte solution.
- If you get erroneous readings after changing the membrane cap and performing the proper calibration, completely change the DO sensor electrolyte solution.

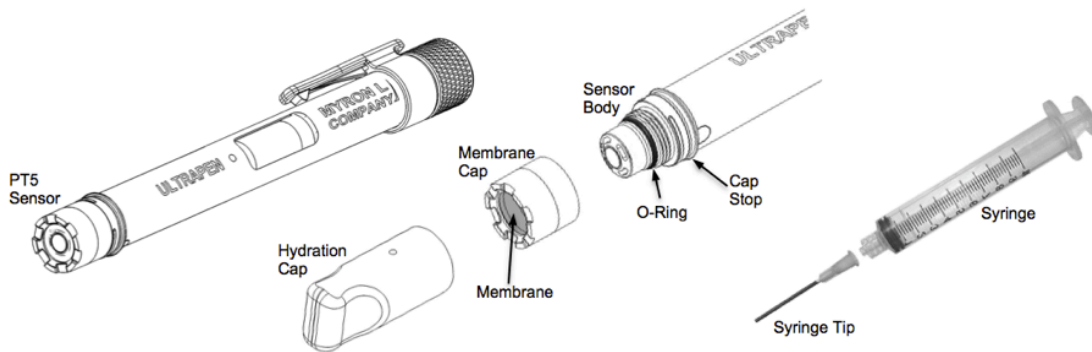

Electrolyte Replacement Procedure

1. Unscrew the membrane cap from the sensor body by turning in a counter-clockwise direction.
2. Discard all the electrolyte solution from the electrolyte well.
3. Assemble the syringe by installing the tip onto the body.
4. Fill the syringe with DO electrolyte solution.
5. Insert the syringe tip into one of the four openings of the sensor body.
6. Hold the PT5 vertically with the DO sensor at the top and the sensor opening facing up and fill the electrolyte well with DO electrolyte solution.
7. Discard all the electrolyte solution from the electrolyte well. This step rinses out the electrolyte well.
8. Insert the syringe tip into one of the four openings of the sensor body as far as it can go inside the electrolyte well.
 - This helps to minimize air bubbles in the sensor electrolyte to improve accuracy.
9. Hold the PT5 vertically with the DO sensor at the top and the sensor opening facing up and slowly fill the electrolyte well with electrolyte. This also helps to minimize air bubbles.
 - Top off with more electrolyte after removing the syringe from the sensor body.
10. Rinse the inside of the membrane cap with electrolyte solution.
11. Pour some electrolyte inside the membrane cap to minimize air bubbles that may occur during assembly.
12. Hold the electrolyte filled sensor body in one hand and bring the electrolyte filled membrane cap closer with your other hand.
13. Tilt the membrane cap and place it onto the sensor body.
14. Carefully start turning the membrane cap clockwise until it tightens firmly to the sensor body.
 - While you are screwing the membrane cap on the sensor body, some electrolyte may escape.
15. Rinse any residual electrolyte from the outside of the sensor body with clean water (DI, RO or distilled).
16. Fill the hydration cap with enough clean water to soak the sponge inside (preferably DI, RO, or distilled water).
17. Place the hydration cap onto the DO sensor all the way to the cap stop.
18. Let the new sensor stabilize for 2-4 hours with the hydration cap installed before using the PT5 again.

IV. BATTERY REPLACEMENT

The PT5 display has an indicator that depicts the PT5's battery charge level. When the charge level indicator only shows one bar, immediately replace the battery with a new N type battery.

1. In a **CLEAN DRY** place unscrew the battery cap in a counter-clockwise motion.
2. Slide the cap and battery housing out of the PT5.
3. Remove the depleted battery from its housing.
4. Insert a new battery into the battery housing oriented with the negative end touching the spring.
5. Align the groove along the battery housing with the guide bump inside the PT5 case and slide the battery housing back in.
6. Screw the battery cap back on in a clockwise direction. Do not over tighten.

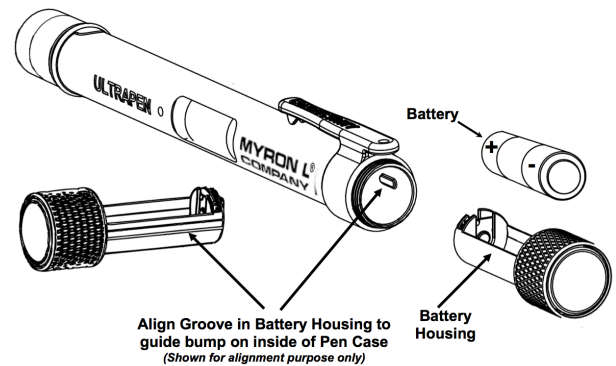

V. DO MEMBRANE REPLACEMENT

If the sensor gives erroneous readings after calibration, replace the membrane cap.

NOTE: The following conditions may cause the DO membrane to require more frequent replacement.

- Using the PT5 in extreme test conditions (e.g. high temperature) may degrade the membrane material.
- The membrane material can be clogged due to the white zinc oxide particles detaching from the zinc coil or contamination due to oils.
- If the membrane becomes ripped, dented, punctured, or otherwise damaged, replace it immediately.
- Always avoid touching the membrane.

Membrane Replacement Procedure

NOTE: Avoid touching the membrane surface at all times.

1. Remove the older membrane cap from the sensor body by turning it counter clockwise.
 - The sensor will lose some electrolyte.
2. Fill the syringe with electrolyte solution.
3. Replace the electrolyte that was lost during the removal of the membrane cap by:
 - a. Hold the PT5 vertically with the DO sensor at the top and the sensor opening facing up.
 - b. Insert the syringe tip through one of the four openings in the sensor body as far as it can go inside the electrolyte well. This helps to minimize air bubbles in the sensor electrolyte to improve accuracy.
 - c. Slowly fill the electrolyte well. Top off with more electrolyte after removing the syringe from the sensor body. This also helps to minimize air bubbles.
4. Pour some electrolyte inside the membrane cap as well to minimize air bubbles.
5. Hold the electrolyte filled sensor body in one hand and bring the electrolyte filled membrane cap closer with your other hand.
6. Tilt the membrane cap and place it onto the sensor body.
7. Carefully start turning the membrane cap clockwise until it firmly tightens to the sensor body.
 - While you are screwing the membrane cap on the sensor body, some electrolyte may escape.
8. Rinse any residual electrolyte from the outside of the sensor body with clean water (DI, RO or distilled).
9. Fill the hydration cap with just enough water (DI, RO, or distilled water) to soak the sponge inside.
10. Place the hydration cap onto the DO sensor all the way to the cap stop.
11. Let the new membrane cap activate for 2-4 hours with the hydration cap installed before using the PT5 again.

NOTE: If the sensor O-ring is damaged or lost, replace it with the new O-ring that was included in the kit (Part # DOM5K).

VI. CLEANING THE DO SENSOR

The PT5's DO sensor does not need frequent cleaning. Usually replacing the electrolyte solution and/or replacing the membrane cap rejuvenates the sensor.

NOTES: The sensor is continuously oxidizing and reducing even while unused.

- When too many white zinc oxide particles form on the zinc electrode, clean the sensor (you may need to remove the sensor from the PT5 to see the zinc oxide particles inside the sensor).
- Large amounts of zinc oxide particles can clog the DO membrane.
- If it has been a long time since the PT5 was used, clean the zinc coil and replenish the sensor with fresh electrolyte.
- Always avoid touching the membrane or silver cathode, as oil from your fingers will compromise measurements.

Myron L[®] Company – **ULTRAPEN™ PT5** – Operation Manual
Dissolved Oxygen (DO) and Temperature Pen

Cleaning Procedure

1. Remove the membrane cap by turning it counterclockwise and place it to the side.
 - If you are going to reuse the membrane cap gently wash it with clean water (preferably DI, RO, or distilled water) to get rid of any particles that may have built up during use.
 - **BE CAREFUL** not to damage the membrane.
2. Discard all the electrolyte solution from the electrolyte well.
3. Fill a clean syringe with white vinegar
4. Hold the PT5 vertically with the sensor at the top,
5. Insert the syringe tip into one of the four openings of the sensor body as far as it can go inside the electrolyte well.
6. Inject vinegar into the electrolyte well until the sensor is filled to the top.
7. Leave the vinegar inside the electrolyte well for 5 minutes.
8. Discard the vinegar.
9. Clean the syringe thoroughly with clean water (DI, RO, or distilled).
10. Fill the syringe with DI, RO, or distilled water.
11. Holding the open sensor sideways or upside down over a sink insert the syringe tip into one of the four openings of the sensor body and thoroughly flush the electrolyte well with clean water (DI, RO or distilled). Repeat 3-4 times.
12. Fill a new syringe with DO electrolyte solution.
 - **DO NOT USE** the same syringe to refill the electrolyte well with electrolyte that you have previously used to clean the sensor.
13. Holding the open sensor sideways or upside down over a sink insert the syringe tip into one of the four openings of the sensor body and thoroughly flush the electrolyte well with electrolyte solution.
14. Refill the syringe with DO electrolyte solution.
15. Insert the syringe tip into one of the four openings of the sensor body as far as it can go inside the electrolyte well.
 - This helps to minimize air bubbles in the sensor electrolyte to improve accuracy.
16. Hold the PT5 vertically with the DO sensor at the top and the sensor opening facing up and slowly fill the electrolyte well with electrolyte. This also helps to minimize air bubbles.
 - Top off with more electrolyte after removing the syringe from the sensor body.
17. Pour some electrolyte inside the membrane cap as well to minimize air bubbles that may occur during assembly.
18. Hold the electrolyte filled sensor body in one hand and bring the electrolyte filled membrane cap closer with your other hand.
19. Tilt the membrane cap and place it onto the sensor body.
20. Carefully start turning the membrane cap clockwise until it tightens firmly to the sensor body.
 - While you are screwing the membrane cap on the sensor body, some electrolyte may escape.
21. Rinse any residual electrolyte from the outside of the sensor body with clean water (DI, RO or distilled).
22. Fill the hydration cap with enough clean water to soak the sponge inside (preferably DI, RO, or distilled water).
23. Place the hydration cap onto the DO sensor all the way to the cap stop.
24. Let the new sensor stabilize for 2-4 hours with the hydration cap installed before using the PT5 again.

STORAGE

The PT5 sensor is continuously oxidizing and reducing even while unused, causing white zinc oxide particles to buildup inside the sensor. If you need to store the PT5, follow the instructions below.

Short-term storage (less than a month):

The sensor should be kept moist with the hydration cap containing a sponge moistened with DI, RO or distilled water.

Long-term storage (a month or longer):

After setup, the zinc anode will be immersed in electrolyte solution and will be continuously oxidizing, even while unused. For long-term storage it is best to remove the electrolyte, rinse the sensor and membrane cap, and store it dry. You should also remove the battery from the PT5.

To prepare the sensor for long term storage:

1. Remove the membrane cap by turning it counterclockwise.
2. Rinse the membrane cap thoroughly with DI, RO, or distilled water, gently pat it dry with a soft lint-free cloth, and place it to the side.
 - **BE CAREFUL** not to harm the membrane.
3. Discard all the electrolyte solution from the sensor's electrolyte well.
4. Fill a syringe with DI, RO, or distilled water.
5. Holding the open sensor sideways or upside down over a sink insert the syringe tip into one of the four openings of the sensor body and thoroughly flush the electrolyte well with DI, RO or distilled water. Shake all the water out of the sensor, and repeat 3-4 times.

Dissolved Oxygen (DO) and Temperature Pen

6. Shake all the water from the sensor, pat dry with a soft lint-free cloth, and allow the sensor to completely dry out.
7. Remove the sponge from the hydration cap.
8. Rinse the hydration cap with clean water then dry it with a soft lint-free cloth.
9. Once the sensor, membrane cap, and hydration cap are thoroughly dry, reinstall the membrane cap and hydration cap.
 - The foam from the hydration cap should be stored separately, as any moisture in the sensor will promote oxidation.
10. Remove the battery from the PT5.
11. Store the PT5 in a cool dry location.

NOTE: When you are ready to use the PT5 after long-term storage, follow the sensor setup instructions. Verify the membrane is not torn or otherwise damaged. If oxidation is present inside the sensor, clean the sensor prior to sensor setup (see MAINTENANCE section VI).

SPECIFICATIONS

	DO Concentration	DO Saturation	Temperature
Ranges	0-20 ppm	0-200%	0-71°C / 32-160°F
Accuracy¹	±0.2 ppm or ±2% of the reading, whichever is greater (up to 40°C)	0.0% to ≤ 100.0%: ± 20 counts; >100%: ± 2% of the reading.	± 0.1°C
Resolution	0.01 ppm	0.1%	0.1°C/F
Altitude Adjustment: -2,000 ft. to 15,000 ft. in increments of 100 ft.			
Salinity Adjustment: 0 - 50 ppt in increments of 1 ppt			
Time to Reading Stabilization: 10 - 180 seconds			
Calibration Methods: 1 or 2 Point; 0 ppm DO Calibration Solution, Air or Water			
Operating / Storage Temperature: 0-55°C / 32-131°F			
Power Consumption: Active Mode: 33 - 140 mA, Sleep Mode: 2 µA			
Temperature Compensation for Membrane permeability: Automatic			
Physical Dimensions: 17.15 cm L x 1.59 cm D or 6.75 in. L x .625 in. D			
Weight: 54 g or 1.94 oz.			
Case Material: Anodized Aircraft Aluminum with Protective Coating			
Battery Type: N type, Alkaline 1.5 V			
Water Resistance: IP67 and NEMA 6			
EN61236-1: 2006 - Annex A: 2008; 1999/5/EC Annex III:			
Electrostatic discharge to case of instrument may cause PT5 to spontaneously power ON. In this case, the PT5 will power OFF after several seconds.			
¹ Accuracy after Temperature Controlled, Full Calibration.			

ACCESSORIES

STANDARD SOLUTIONS:

The ULTRAPEN™ PT5 can be calibrated in Air or Water, or with 0 ppm Dissolved Oxygen Solution.

Order Models:

- **DOSOL** 0 ppm Dissolved Oxygen Calibration Solution

REPLACEMENT AND CONSUMABLE ITEMS:

The ULTRAPEN™ PT5 features user replaceable sensor membranes and electrolyte.

Order Models:

- **DOM5** DO Membrane 5pk.
- **DOSRE** DO Sensor Replenishment Electrolyte 2 oz.
- **DORS** DO Replenishment Syringe w/Tip
- **DOM5K** DO Membrane 5pk, Replenishment Electrolyte 2 oz., Syringe w/Tip Kit, and instruction sheet.

MYRON L[®] WARRANTY

The PT5, excluding the sensor and Battery, has a one (1) year limited warranty